

KFC-1382

SERVICE MANUAL

KENWOOD

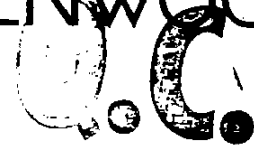

COPY

©1988-10 PRINTED IN JAPAN
B51-3692-00(B)1878

EXTERNAL VIEW

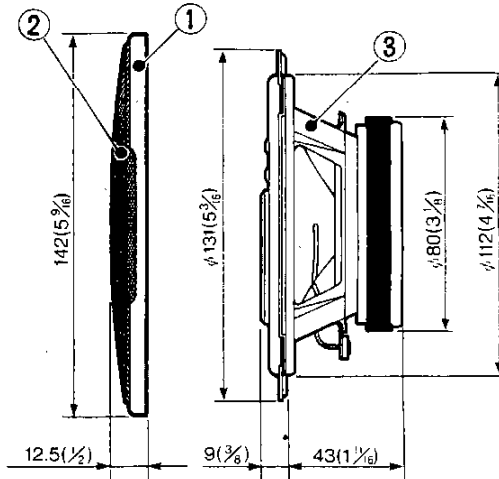
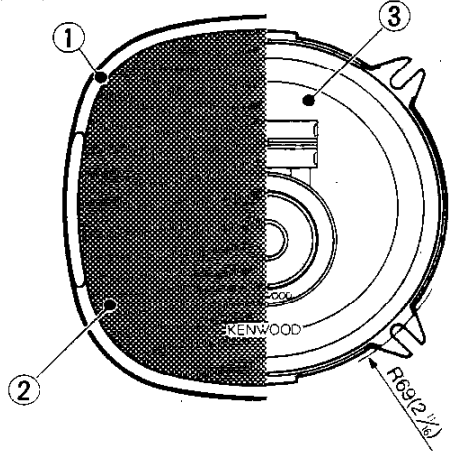

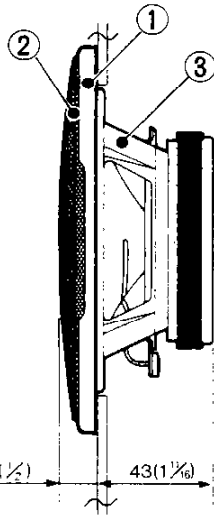

UNIT: mm (inch)



UNIT: mm (inch)

PARTS INCLUDED

-  4.5m (15ft) x 2
-  ϕ 4-20($\frac{3}{16}$ - $\frac{3}{4}$) x 8
-  x 8

SPECIFICATIONS

- Speakers
- Woofer 13cm(5 1/4 in) Water proof treatment cone type 167g(6 oz) Magnet
 - Mid-Range 4cm(1 5/8 in) cone type
 - Tweeter Ceramic
 - Peak power 60 Watts
 - Frequency Response 50Hz ~ 21,000Hz
 - Sensitivity 90 dB/W at 1m
 - Impedance 4 ohms
 - Weight per speaker with grille 0.64kg(1lb 7oz)/pc

We follow a policy of advancements in development.
For this reason specifications may be changed without notice.

PARTS LIST

★ New parts
Parts without **Parts No.** are not supplied.
Les articles non mentionnés dans le **Parts No.** ne sont pas fournis
Teile ohne **Parts No.** werden nicht geliefert.

Ref No.	New Parts	Parts No.	Description
①	★	B06-0318-08	FRONT GRILLE
	★	E30-1237-08	CORD SET
②	★	F09-0888-08	PROTECTOR
	★	N99-1088-08	SCREW SET
③	★	T15-0125-08	SPEAKER